

# NARVA®

Part No. 71732, 71734

## **ULTIMA 180 MK3 HYBRID LED DRIVING LIGHT**

### **INSTRUCTIONS AND SPECIFICATIONS**



#### **IMPORTANT SAFETY INFORMATION**

**Please read these instructions carefully before installation.**

- Remove negative battery cable before installation.
- Ensure lamps are fitted using the appropriate wiring harness or an equivalent auxiliary wiring system.

**We strongly recommend to use the Ultima LED Wiring Harness (74407)**

- Ensure the lamps are mounted securely to a solid surface on the vehicle or bullbar.
- Cables connected to the lamp must not be subjected to wear or other damage.

## MOUNTING

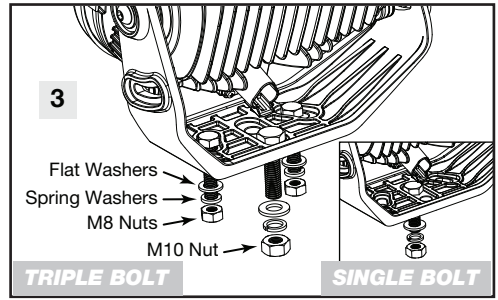
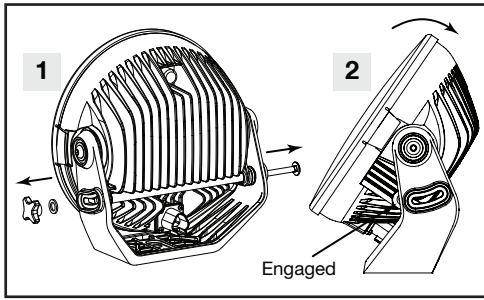

1. Remove Adjuster Knob, Flat Washer and Long Bolt.
2. Tilt lamp backwards to allow access to insert the mounting bolts (Ensure the lamp is still engaged with the bracket).
3. Place the mounting bolts through the holes in bracket. Note, 3 bolts are advised, if single bolt only, mount in centre hole.
4. Re-assemble the Adjuster Knob, Flat Washer and Long Bolt in reverse order.
5. Choose a solid surface on the vehicle or bullbar to mount the driving lights and secure the lamp by using flat washers, spring washers with M10 & M8 nuts.
6. Ensure the Adjuster Knob is done up tight.

## ASSEMBLIES

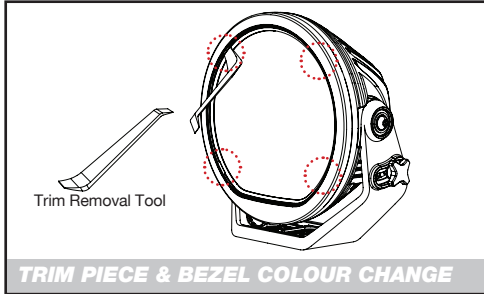

To change the colour trim or bezel, use the trim removal tool provided to lift up the bezel in the slits of each corner circled.

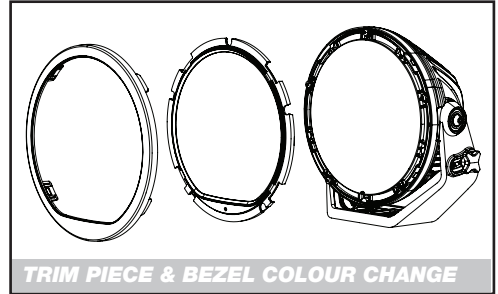

Re-assemble by simply snap locking the colour trim and bezel to the housing.

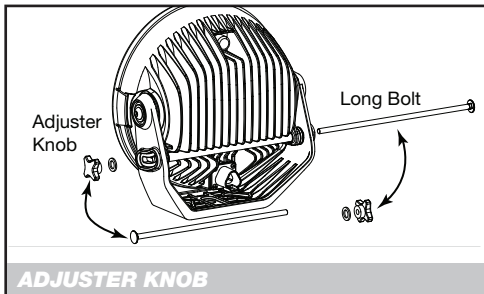

Adjuster Knob can be reversed from left hand to right hand side.

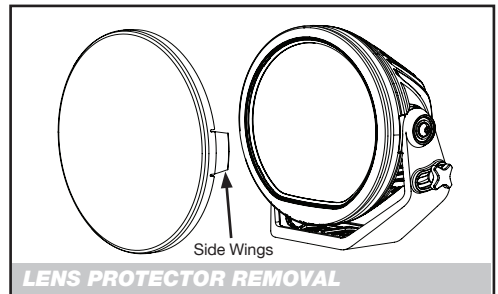

Remove Lens Protector by un-clipping the side wings.

# ULTIMA LED HYBRID WIRING HARNESS USING SWITCH & RELAY\*

\*Included in 71734

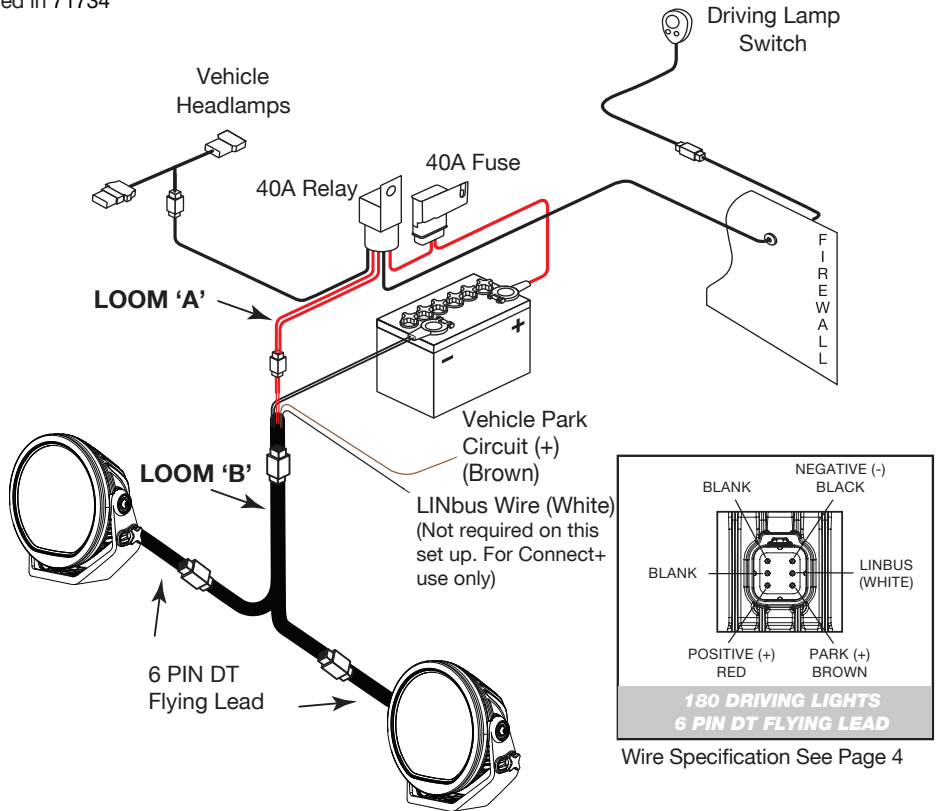

## WARNING:

**One wiring harness to be used per 2 driving lights. Additional lights connected to the same wiring harness will cause wiring and fuse to burn.**

1. Connect Loom 'B' 6PIN DT connectors to 180 Driving Light DT flying lead sockets.
2. Fix Loom 'B' ground cable to chassis or battery (-).
3. Connect Loom 'A' to Loom 'B'.
4. Mount relay and fuse holder (Ensure these are mounted in a dry area of the engine bay)
5. Connect main positive cable with 40Amp relay from fuse holder to battery (+).
6. The kit is supplied with a pre-wired H4 loom assembly for direct connection to the vehicle headlamp high beam circuit. For globe types other than H4, an additional adapter kit (P/No. 74416) is available to suit H1, H3 and H7 globe types.
7. A direct connection from the vehicle high beam circuit to any alternate light source can be made by connecting the black wire to negative and red wire to positive.
8. Pass Loom 'A' 3 core lead through the firewall and connect to Driving Light Switch.
9. Test the driving light by turning on the vehicle's headlamps  
The driving light should only illuminate on high beam.

**Note:** Driving lights must dip with H/Beam to meet ADR requirements. LINbus wire connection only required with Ultima Connect+ Controller. "High Beam Splitter" included if multiple wiring harnesses are used and require high beam feed.

# ULTIMA 180 HYBRID WIRING INSTRUCTIONS FOR CONNECT+ CONTROLLER INSTALL ONLY

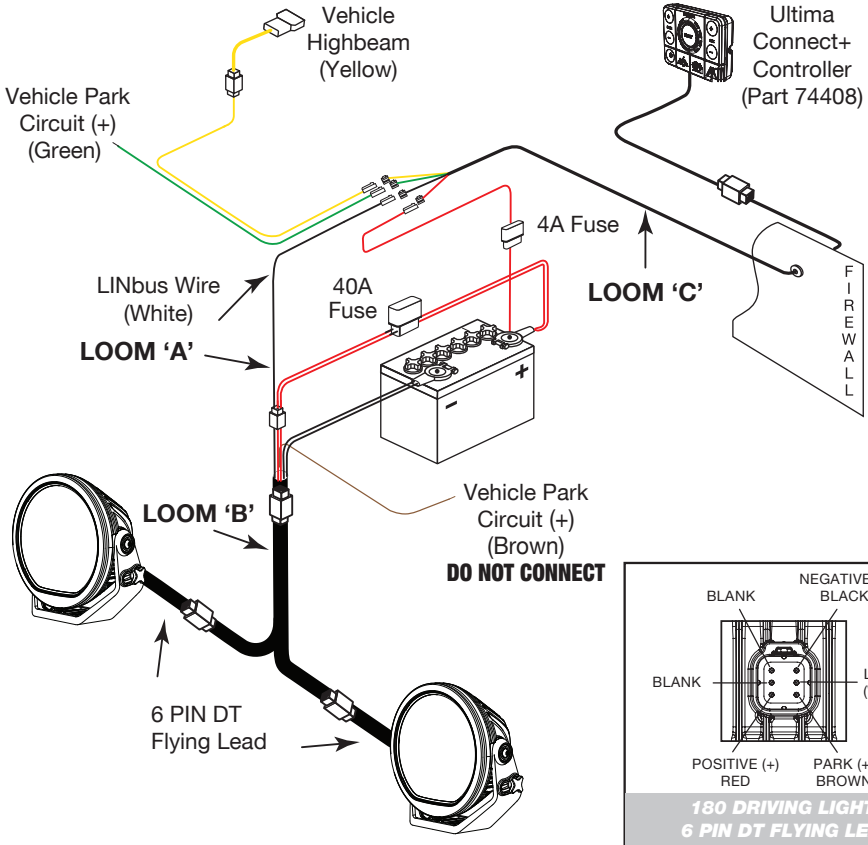

## 6-PIN DT FLYING LEAD WIRE SPECIFICATION

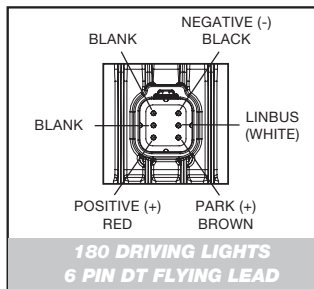

**PIN 1** Negative Black 4MM (16AWG)

**PIN 2** Linbus White 2.5MM (20AWG)

**PIN 3** Park Brown 2.5MM (20AWG)

**PIN 4** Positive Red 4MM (16AWG)

**PIN 5** Blank - Not in use for 180 MK3

**PIN 6** Blank - Not in use for 180 MK3

## WARNING:

**One wiring harness to be used per 2 driving lights. Additional lights connected to the same wiring harness will cause wiring and fuse to burn.**

1. Connect Loom 'B' 6PIN DT connectors to 180 Driving Light DT flying lead sockets.
2. Fix Loom 'B' ground cable to chassis or battery (-).
3. The kit is supplied with a pre-wired H4 loom assembly for direct connection to the vehicle headlamp high beam circuit. For globe types other than H4, an additional adapter kit (Narva P/No. 74416) is available to suit H1, H3 and H7 globe types.
4. A direct connection from the vehicle high beam circuit can be made by connecting to the yellow wire from Loom 'C' of the Connect+ harness. Use yellow "High beam adapter extension" if extra length is required.  
**Note:** See below for Negative Switching instructions
5. Connect the Green wire from Loom 'C' Connect+ harness to vehicle park light circuit or ignition source (+).  
**Note:** Do not connect Park (+) Brown wire from 180 Driving Light when using Connect+
6. Connect white LINbus wires from Loom 'B' to Loom 'C'. If using 2 or more harnesses, use the white LINbus wire splitter. Every Connect+ enabled product will need to be connected to the white LINbus wire for full functionality.
7. Pass Loom 'C' through the firewall and connect to Connect+ Controller.
8. Connect main red positive cable with 40Amp fuse in-line to Loom 'B'. Do not use relay harness for Connect+ install.
9. Connect red positive cable with 4Amp fuse in-line to Loom 'C' Connect+ harness.
10. Mount fuse holder (Ensure these are mounted in a dry area of the engine bay).
11. Connect all red positive cables to battery (+) from Loom 'A' and Loom 'C'.
12. Test the Connect+ controller by turning vehicle ignition or parking lights on. Power button on Connect+ should illuminate white.
13. Test the driving lights by turning on the vehicle's park light and high beams. Press the Power button on Connect+ when illuminated green to turn driving lights on. The driving lights should only illuminate on high beam.

**Note:** Driving Lights must dip with H/Beam to meet ADR requirements.  
LINbus wire connection only required with Ultima Connect+ Controller.

## NEGATIVE SWITCHING

For negative switched vehicles:

1. Using a 4PIN normally open relay (Narva P/No. 68000), connect PIN 30 and PIN 85 to a constant +12V source with 5Amp inline fuse.
2. Connect negative (-) high beam wire from vehicle to PIN 86.
3. Connect PIN 87 to Connect+ Controller High beam feed.

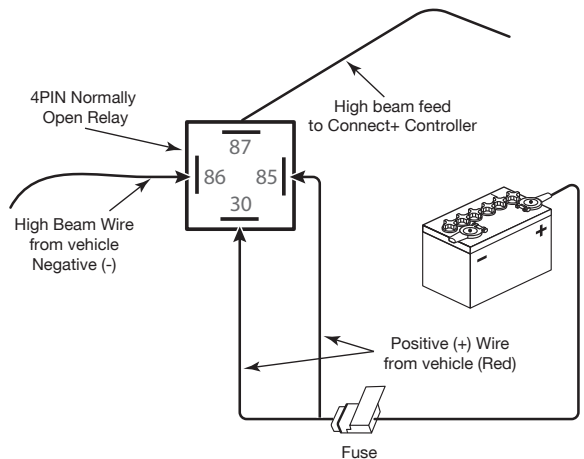

## HOW TO USE CONNECT+ CONTROLLER

### MAIN

#### Controls:

180 Ultima Hybrid Driving Lights  
215 Ultima Hybrid Driving Lights  
24" Ultima Light Bars

Press + to increase brightness  
Press - to decrease brightness

### BOOST

Overrides all modes and thermal protection system for 30 seconds to provide full brightness with an extra 15% power.

BOOST mode will turn off automatically after 30 seconds and cannot be pressed again until 5 minutes later. The boost ring lights up when ready to use

### POWER

White illumination –  
Ignition or Parking  
lights ON

Green illumination –  
High beam ON

Press to turn lights  
ON and OFF when  
green lights is  
illuminated



### AUX

#### Controls:

215 Ultima Spot Driving Lights  
8" Ultima Light Bars

Press + to increase brightness  
Press - to decrease brightness

### DIRT ROAD MODE

Provides 100% brightness on  
all lights

### 4WD TRACK MODE

Provides 50% brightness on  
MAIN and 100% brightness  
on AUX

### HIGHWAY ROAD MODE

Provides 100% brightness on  
MAIN and 50% brightness  
on AUX

## TECHNICAL SPECIFICATIONS - FOR 71732 & 71734

Voltage:	12/24 Dual voltage with reverse polarity protection
LEDs:	24 x 5W Osram LEDs
Housing and Bracket:	Pressure die-cast aluminium housing and bracket
Beam Type:	Hybrid Beam Pattern
Lens:	Polycarbonate
Colour Temperature:	5700°K
Current Draw (per lamp):	9.45A at 13.5V

## **PARTS AVAILABLE**

<b>74407</b>	Ultima LED Wiring Harness to suit 71732, 71734, 71742, 71744 and 71745
<b>72223</b>	Ultima 180 LED – Lens Protector Clear
<b>72223BK</b>	Ultima 180 LED – Lens Protector Black
<b>72223BLK</b>	Ultima 180 LED - Alternate LED Protector
<b>72223YW</b>	Ultima 180 LED - Lens Protector Selective Yellow
<b>74142B</b>	Ultima 180 LED – Metal Bezel (Black)
<b>74142S</b>	Ultima 180 LED – Metal Bezel (Satin)
<b>74147</b>	Bullbar adaptor plate kit
<b>74436</b>	Ultima 180 LED – Adjustment Bolt and Knob
<b>74436BK</b>	Ultima 180 LED – Adjustment Bolt and Knob Black
<b>74435</b>	Ultima 180 LED – Bracket Kit

## **WARRANTY STATEMENT**

Brown & Watson International Pty Ltd ("BWI") of 1500 Ferntree Gully Road, Knoxfield, Vic., telephone (03) 9730 6000, fax (03) 9730 6050, warrants that all products described in its current catalogue will under normal use and service be free of failures in material and workmanship for a period of three (3) years from the date of the original purchase by the customer as marked on the invoice. This warranty does not cover ordinary wear and tear, abuse, alteration of products or damage caused by the purchaser. To make a warranty claim the consumer must deliver the product at their cost to the original place of purchase or to any other place which may be nominated by either BWI or the retailer from where the product was bought in order that the warranty assessment may be performed. The consumer must also deliver the original invoice evidencing the date and place of purchase together with an explanation in writing as to the nature of the claim. In the event that the claim is determined to be for a minor failure of the product then BWI reserves the right to repair or replace it at its discretion. In the event that a major failure is determined the consumer will be entitled to a replacement or a refund as well as compensation for any other reasonably foreseeable loss or damage. This warranty is in addition to any other rights or remedies that the consumer may have under State or Federal legislation.

## **IMPORTANT NOTE**

Our goods come with guarantees that cannot be excluded under the Australian Consumer Law. You are entitled to a replacement or refund for a major failure and compensation for any other reasonably foreseeable loss or damage. You are also entitled to have the goods repaired or replaced if the goods fail to be of acceptable quality and the failure does not amount to a major failure.

### **Distributed by**

#### **AUSTRALIA**

**Brown & Watson International Pty. Ltd.**

Knoxfield, Victoria 3180

Phone: (03) 9730 6000

Fax: (03) 9730 6050

National Toll Free: 1800 113 443

#### **NEW ZEALAND OFFICE**

**Brown & Watson International NZ Ltd.**

Mount Wellington, Auckland 1060

Phone: (09) 525 4575