

# NARVA®

## INSTRUCTION SHEET

P/No.s 98850, 98856, 98850HD, 98856HD, 98850HD-D, 98856HD-D

## L.E.D TRAILER LAMP

### ADR FITTING INSTRUCTIONS

Orientation: Rearward facing with lamp's long axis horizontal. Indicator function should be at vehicle's edge

### MODEL 88 MOUNTING HOLE POSITIONS

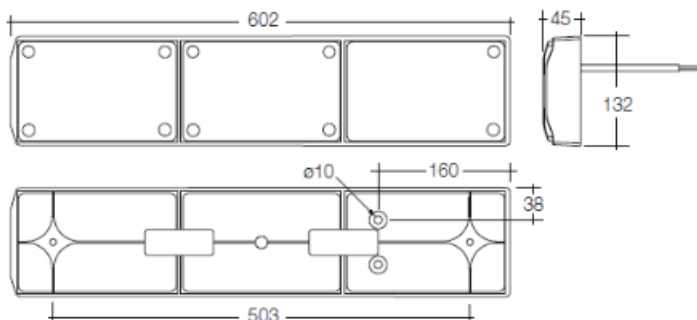

### WIRING INSTRUCTIONS

White: Earth (-)  
Brown: Tail (+)

Red: Stop (+)  
Green: Indicator (+)

Black: Reverse (+)\*

\*where applicable

Note: To avoid damage to the end caps base it is important the lamp removal instructions are followed as per below

## LAMP REMOVAL INSTRUCTIONS

- 1 Using a small flat tip screw driver, carefully remove the screw caps

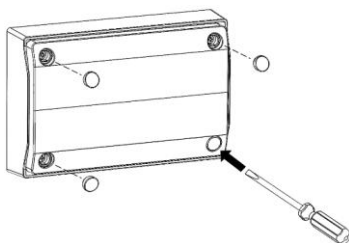

- 2 Remove 4x Phillips Head screws & remove the Lamp

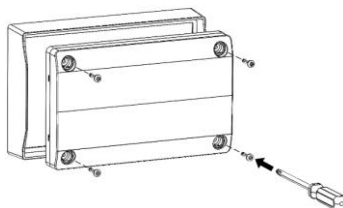

Distributed by:

**Brown & Watson Int. Pty Ltd**

1500 Ferntree Gully Road, Knoxfield, Victoria 3180

**[www.narva.com.au](http://www.narva.com.au)**

### WARRANTY STATEMENT

Applicable only to product sold in Australia

Brown & Watson International Pty Ltd of 1500 Ferntree Gully Road, Knoxfield, Vic., telephone (03) 9730 6000, fax (03) 9730 6050, warrants that all products described in its current catalogue (save and except for all bulbs and lenses whether made of glass or some other substance) will under normal use and service be free of failures in material and workmanship for a period of one (1) year (unless this period has been extended as indicated elsewhere) from the date of the original purchase by the consumer as marked on the invoice. This warranty does not cover ordinary wear and tear, abuse, alteration of products or damage caused by the consumer.

To make a warranty claim the consumer must deliver the product at their cost to the original place of purchase or to any other place which may be nominated by either BWI or the retailer from where the product was bought in order that a warranty assessment may be performed. The consumer must also deliver the original invoice evidencing the date and place of purchase together with an explanation in writing as to the nature of the claim.

In the event that the claim is determined to be for a minor failure of the product then BWI reserves the right to repair or replace it at its discretion. In the event that a major failure is determined the consumer will be entitled to a replacement or a refund as well as compensation for any other reasonably foreseeable loss or damage.

This warranty is in addition to any other rights or remedies that the consumer may have under State or Federal legislation.

### IMPORTANT NOTE

Our goods come with guarantees that cannot be excluded under the Australian Consumer Law. You are entitled to a replacement or refund for a major failure and compensation for any other reasonably foreseeable loss or damage. You are also entitled to have the goods repaired or replaced if the goods fail to be of acceptable quality and the failure does not amount to a major failure.