

NARVA®

AEROTECH™

L.E.D STROBE/ROTATOR

Amber, SAE Class 1, ECE R65 Class 1 and 2

***Instructions, Specifications
& Warranty Details***



P/No. 85600A, 85601A, 85602A, 85603A, 85604A,
85606A, 85607A, 85608A, 85609A, 85610A, 85612A,
85613A, 85614A, 85615A, 85616A



INSTALLATION – FLANGE BASE

- 1 Prepare a suitable area on the vehicle's surface by wiping it clean to prevent scratching.
- 2 Drill a 10mm ($\frac{3}{8}$ ") hole into the surface for the wires to exit through for connection to a power source. Alternatively, the wires can be directed through the side of lamp's base for connection to a power source.
- 3 Choose mounting orientation – ensure the product is square.
See page 4 for more information.
- 4 Using the supplied lamp gasket as a template, drill three 4.7mm ($\frac{6}{16}$ ") holes for fitment and secure to the surface using the supplied mounting bolts. A mounting pad is included and can be installed between the surface and the lamp.
- 5 Route the wires as planned in step 2. Connect the red (+) wire to 10–33V DC and the black (-) wire to ground. Test.

Note: 63235BL can be used to either change pattern or power mode in one switch.

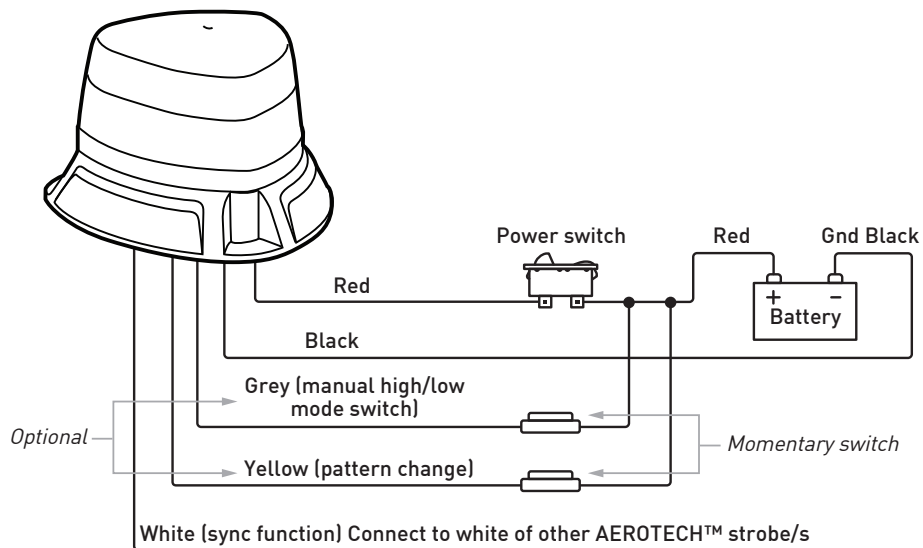

Note: To ensure that the light sensor works correctly don't cover the top of the strobe otherwise the sensor will register as night mode. Then you will need to connect the override wire (Grey) to a momentary switch to allow them to switch to "High/Low power mode".

FEATURES

- High power LED's ensure AeroTech™ exceeds SAE Class 1
- Aerodynamic shape for reduced wind noise in high speed applications
- Ultra-sonic sealing provides total protection against water/dust (IP67)
- Virtually unbreakable polycarbonate lens
- Heavy duty polycarbonate base
- Ambient light sensor with optional low and high power modes
- Four flash patterns including rotating
- Allows synchronisation of up to 6 units (Flange mount only)
- Reverse polarity and transient current protected
- Operating temperature: -30°C – +60°C
- Vibration and shock resistant – tested to IEC 60068-2-29, ISO 16750-3: 2007, ISO 16750-4:2010
- CISPR25 Class 3 approved for reduce RFI
- EMC, RoHS and REACH compliant

WIRING

RED: To 10–33V DC(+)

BLACK: To chassis / ground (-)

YELLOW: Flash pattern selection (+)

WHITE: Synchronization. Connect together (3 bolt mount only)

GREY: Sensor Wire - Connect to constant DC Power to activate the light sensor, momentary connection will change between high and low power. If this wire is not connected the strobe will only function in high power

FLASH PATTERNS

The unit comes with 4 user-selectable flash patterns plus steady on

ROTATOR (Default) (SAE)

DOUBLE FLASH (SAE)

CLOCKWISE ROTATOR (SAE)

QUINT FLASH

STEADY ON

*85600A, 85601A, 85602A, 85603A and 85604A are only SAE for rotate. R65 model available.

TA1 = ECE R65 Class 1 (Night)

TA2 = ECE R65 Class 2 (Day)

MOUNTING ORIENTATION

- The strobe is designed in an aerodynamic shape.
- The most aerodynamic orientation is to face the flat part forwards.
- Facing the point forwards is also an acceptable way to mount.
- The shape also provides increased horizontal illumination on the sides, again facing this forward is the best in most applications.
- However if fitted to the back of a vehicle facing the flat side backwards can provide increased visibility.

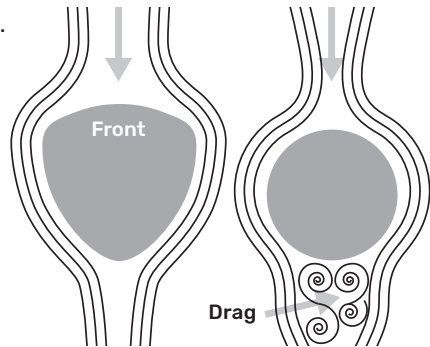

TECHNICAL SPECIFICATIONS

	85600A	85606A	85612A
Operating Voltage	10–33V	10–33V	10–33V
Current Draw @ 12V (Rotate, Flash)	0.6A, 1.4A	1A, 1.6A	1A, 1.6A
Max LED Power	40W	90W	36W
Temp Range (°C)	-30° – 60°	-30° – 60°	-30° – 60°
CISPR 25	3	3	3
R10	✓	✓	✓
R65	Class 1**	Class 2	Class 2
RCM	✓	✓	✓
SAE J845	Class 1	Class 1	Class 1
RoHS	✓	✓	✓
REACH	✓	✓	✓
Transient Protection	✓	✓	✓
Reverse Polarity	✓	✓	✓
Lens Material	Polycarbonate	Polycarbonate	Polycarbonate
Base Material	Polycarbonate	Polycarbonate	Polycarbonate
IP Rating	IP67	IP67	IP67
Ambient Light Sensor	✓	✓	✓
Synchronisable (Flange)	6 Units	6 Units	6 Units
Flash Pattern Count	4 + Steady On	4 + Steady On	4 + Steady On
High/Low Power Modes	✓ (Low = 40%)	✓ (Low = 60%)	✓ (Low = 60%)
Mounting Diameter	Ø130mm	Ø130mm	Ø130mm
Bolt Holes	3	3	3
Height (Flange)	68mm	88mm	130mm
Base Diameter	142mm	142mm	142mm

* Specifications are the same for other bases excluding dimensions

FITTING

When fitting strobe to existing mounting holes use the supplied adaptor plate (not included with 85600A).

- 1 Work out which orientation is required (point forward or flat forward).
- 2 Install the mounting plate in the slots around the edge ensuring the bolt holes for mounting the strobe are in the correct orientation.
- 3 Screw the beacon to the adaptor plate. The cable can go through the bottom or the cable exit on the strobe.

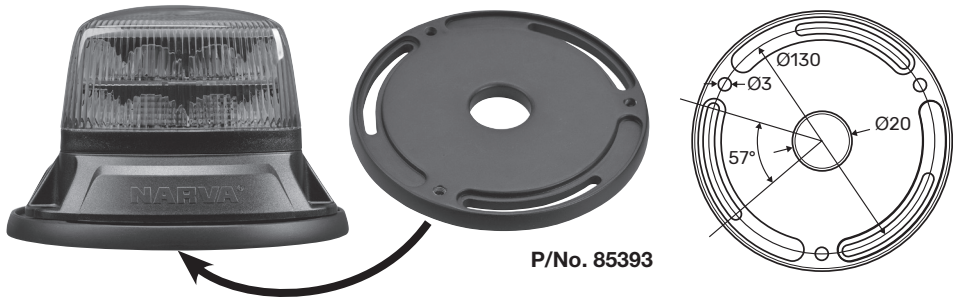

CHANGING BASES

- 1 Unscrew the 3 screws underneath the product.
- 2 Remove the existing base (it may be tight especially 3 bolt mount).
- 3 Disconnect the harness connector.
- 4 Connect the harness with the desired base.
- 5 Be careful with where the connector is fitted.
- 6 Screw the bases together.

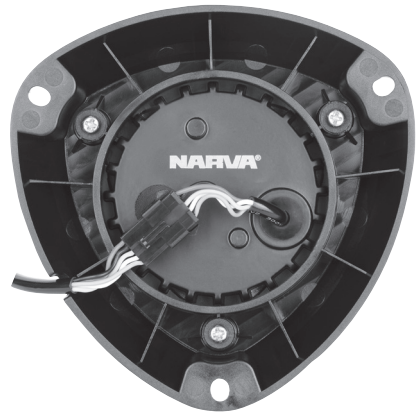

VACUUM MAGNETIC BASE

- 1 To connect the magnetic base remove the flying lead connector and reconnect to the 3 metre spiral cord.
- 2 Fit the magnetic base with the 3 supplied screws.
- 3 When mounting vacuum magnetic base to the roof ensure a dry flat surface and that the vacuum is correctly engaged.

Note: Ensure the cable exits match on the strobe and the magnetic attachment.

PATTERN CHANGE

3 Bolt mount

- 1** Touch the yellow wire to positive power for less than 1 second to move to the next pattern.
 - 2** If the operator desires to change the pattern after installation this can be achieved by adding an extra switch or using a 3 position switch (Off/On/Mom On, P/No. 63235BL).
 - 3** To synchronize patterns connect the white wires of each strobe together.
- * To change the pattern on the flexible pole and DIN pole mount press the button underneath the strobe.
 - * To change the pattern of the magnetic version press the momentary button on the cigarette plug to cycle through the patterns.

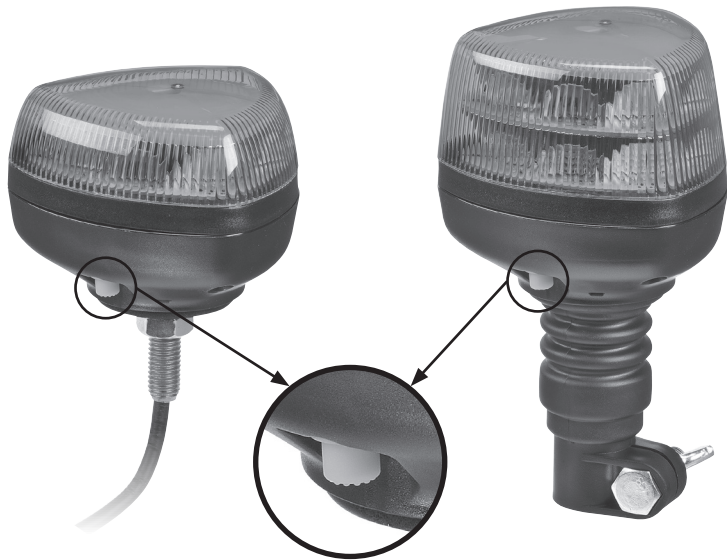

AMBIENT LIGHT SENSOR FUNCTION

The ambient light sensor dims the strobe to 60% of full output. This can be overridden if a momentary switch is wired to the grey wire (+ve). Switch one time for low power, touch again for high power. Once the wire is used the sensor is disabled. To reactivate the sensor turn the beacon off and on again. See full wiring diagram on page 2.

PARTS AVAILABLE

85393	Adaptor Plate T/S Small
85395	3 Bolt
85396	Single Bolt
85397	Standard DIN
85398	Flexi DIN
85399	Suction Mag + DC Cable
85494	Universal Beacon Mounting Plate
63235BL	3 Position Beacon Switch

OUTPUT

AeroTech™ strobes far exceed SAE Class 1 for both rotate and flash. To be SAE approved a product must have a minimum value across the 5 measured zones (-5°, -2.5°, 0°, +2.5°, +5°) of 752 Candela.

AeroTech™ outputs are as follows:

85600A:

Rotate: 2,838 cd (3.7 x brighter than SAE minimum)

Flash: 2,836 cd (3.7 x brighter than SAE minimum)

85606A:

Rotate: 5,053 (6.7 x brighter than SAE minimum)

Flash: 4,637 cd (6.2 x brighter than SAE minimum)

85612A:

Rotate: 4,941 cd (6.6 x brighter than SAE minimum)

Flash: 4,474 cd (6.0 x brighter than SAE minimum)

WARRANTY STATEMENT

Applicable only to product sold in Australia and New Zealand

Brown & Watson International Pty. Ltd. ("BWI") of 1500 Ferntree Gully Road, Knoxfield, Vic., telephone (03) 9730 6000, fax (03) 9730 6050, warrants that all products described in its current catalogue will under normal use and service be free of failures in material and workmanship for a period of one (1) year from the date of the original purchase by the customer as marked on the invoice (see elsewhere for specific warranty period). This warranty does not cover ordinary wear and tear, abuse, alteration of products or damage caused by the purchaser.

To make a warranty claim the consumer must deliver the product at their cost to the original place of purchase or to any other place which may be nominated by either BWI or the retailer from where the product was bought in order that a warranty assessment may be performed. The consumer must also deliver the original invoice evidencing the date and place of purchase together with an explanation in writing as to the nature of the claim.

If the claim is determined to be for a minor failure of the product then BWI reserves the right to repair or replace it at its discretion. If a major failure is determined the consumer will be entitled to a replacement or a refund as well as compensation for any other reasonably foreseeable loss or damage.

This warranty is in addition to any other rights or remedies that the consumer may have under State or Federal legislation.

IMPORTANT NOTE

Our goods come with guarantees that cannot be excluded under the Australian Consumer Law. You are entitled to a replacement or refund for a major failure and compensation for any other reasonably foreseeable loss or damage. You are also entitled to have the goods repaired or replaced if the goods fail to be of acceptable quality and the failure does not amount to a major failure, 7 year warranty excludes physical abuse, chemical abuse and mining applications.

Distributed by

AUSTRALIA

Brown & Watson International Pty. Ltd.

Knoxfield Victoria 3180

Phone: (03) 9730 6000

Fax: (03) 9730 6050

National Toll Free: 1800 113 443

NEW ZEALAND OFFICE

Griffiths Equipment Ltd.

19 Bell Avenue,

Mount Wellington,

Auckland 1060, New Zealand

Phone: (09) 525 4575

Fax: (09) 579 1192

www.narva.com.au

IS484

Issue 1 27.04.21